

**NOT**  
**FOR CONSTRUCTION**  
THESE PLANS HAVE NOT BEEN  
APPROVED AND ARE SUBJECT  
TO CHANGE.

A Landscape Development Plan for  
**Heritage Park**  
**Improvements**  
Foley, Alabama

REFERENCE NOTES SCHEDULE		
32 EXTERIOR IMPROVEMENTS		
CODE	DESCRIPTION	QTY
32-01	PRIMARY COLUMN, TO MATCH EXISTING COLUMNS AT NORT & SOUTH ENTRANCES OF HERITAGE PARK	2
32-02	SECONDARY COLUMN, CMU MASONRY W/ BRICK VENEER	2
32-03	ENTRY WALL, CMU MASONRY W/ BRICK VENEER TO MATCH FOUNTAIN BRICK	72 LF
32-04	PEDESTRIAN PAVERS, CLAY BRICK PAVERS ON FLEXIBLE BASE, BELDEN CITY LINE PAVERS, COLOR: REGIMENTAL RED, WITH SPACER LUGS AND CHAMFERED EDGES, RUNNING BOND PATTERN AS SHOWN	1,784 SF
32-05	CONCRETE SIDEWALK, 5" THK, 3,500 PSI, MEDIUM BROOM FINISH	3,213 SF
32-06	COLUMN, BRICK VENEER W/ CAST STONE CAP AND FINIAL	2

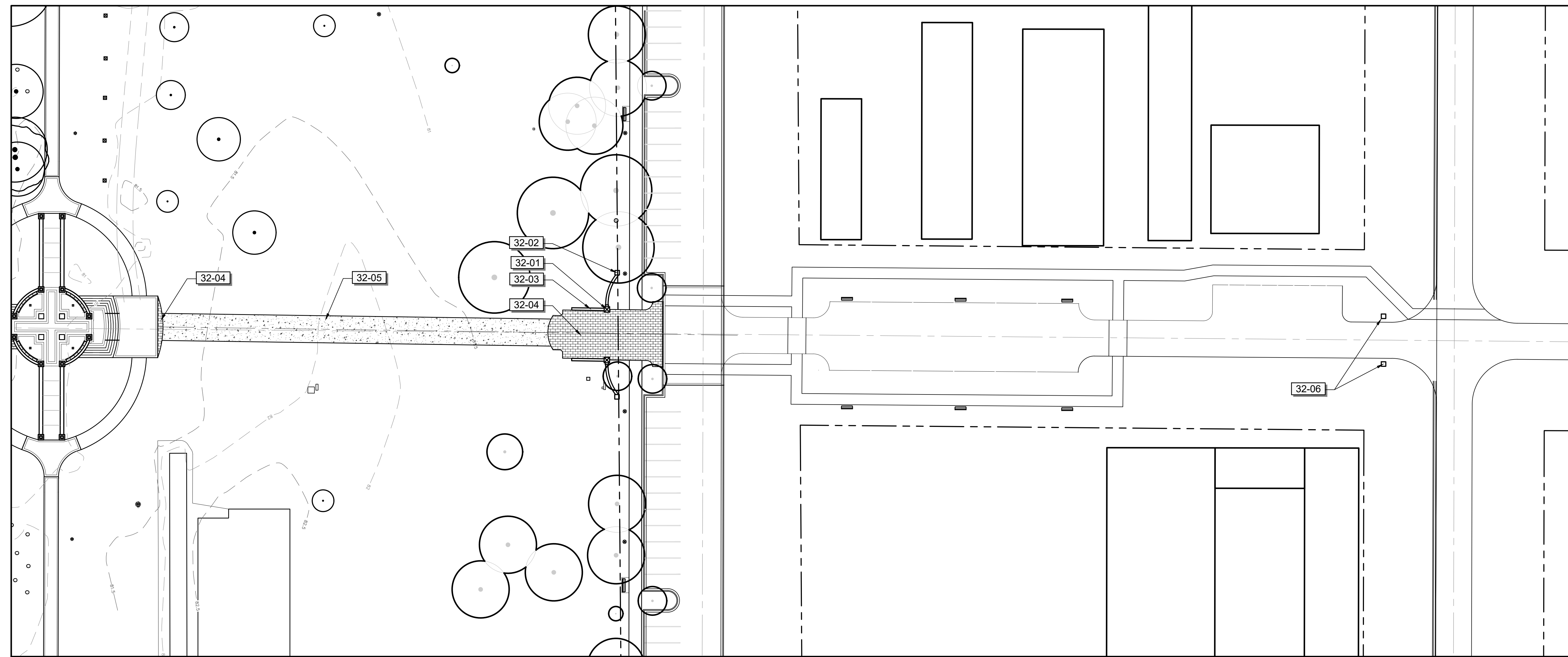

**1** HARDSCAPE PLAN  
Scale: 1" = 30'

Revisions		
No.	Date	Revisions / Submissions
08.26.24		FOR OWNER CONSIDERATION

© Copyright 2024 WAS Design Inc. These documents and their contents are the property of WAS Design. Any reproductions, revisions, modifications or use of these documents without the express written consent of WAS Design is prohibited by law.

BLH	Registration
BLH	Drawn
BLH	Project Manager
LCW	Principal
226003-019	MEMBER
06.01.23	518
Date	

Sheet Title

**HARDSCAPE PLAN**

Sheet No.

**LH100**



**NOT  
FOR CONSTRUCTION**  
THESE PLANS HAVE NOT BEEN  
APPROVED AND ARE SUBJECT  
TO CHANGE.

A Landscape Development Plan for  
**Heritage Park  
Improvements**  
Foley, Alabama

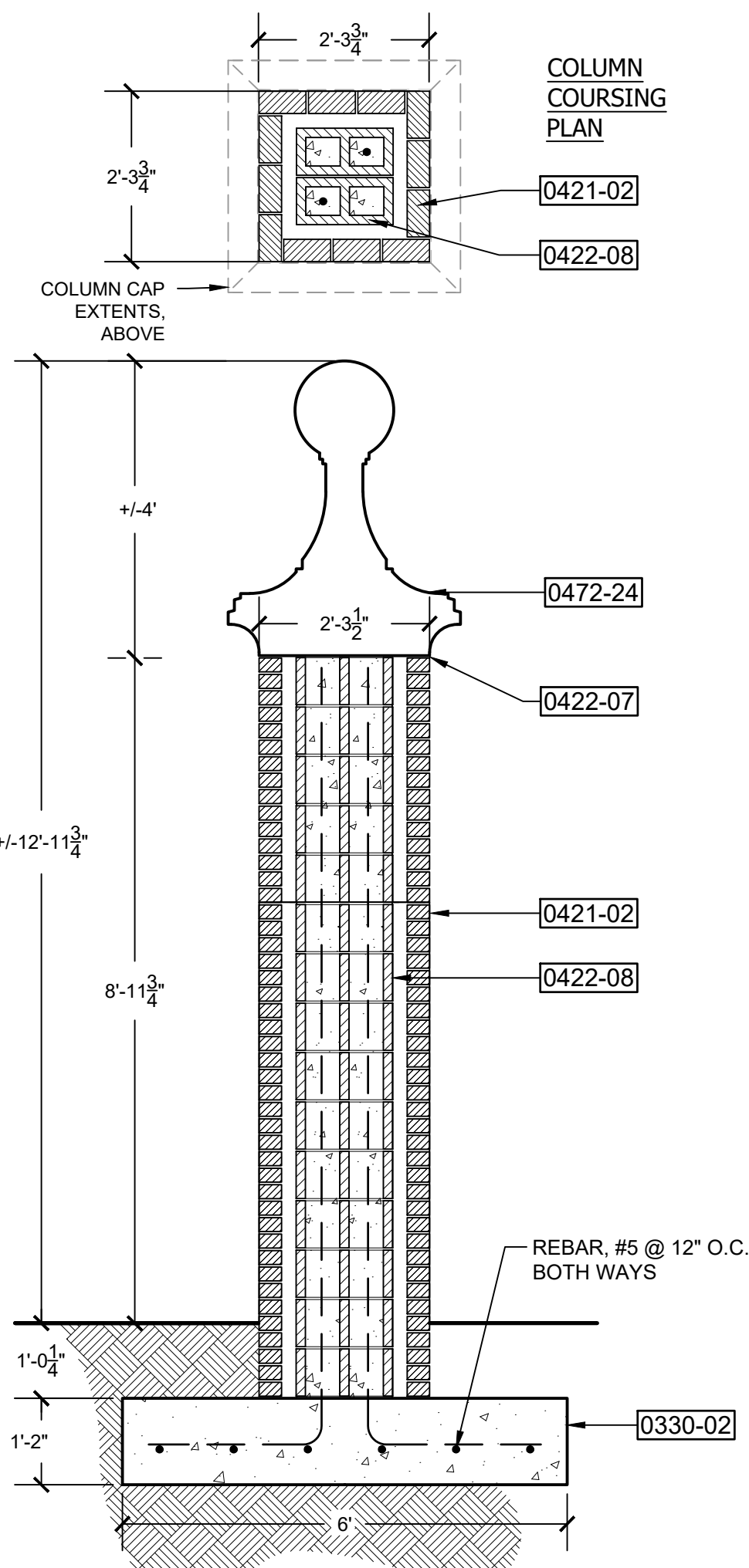

**3 COLUMN AT ENTRANCE**  
1/2" = 1'-0" S-CO-FRT-03

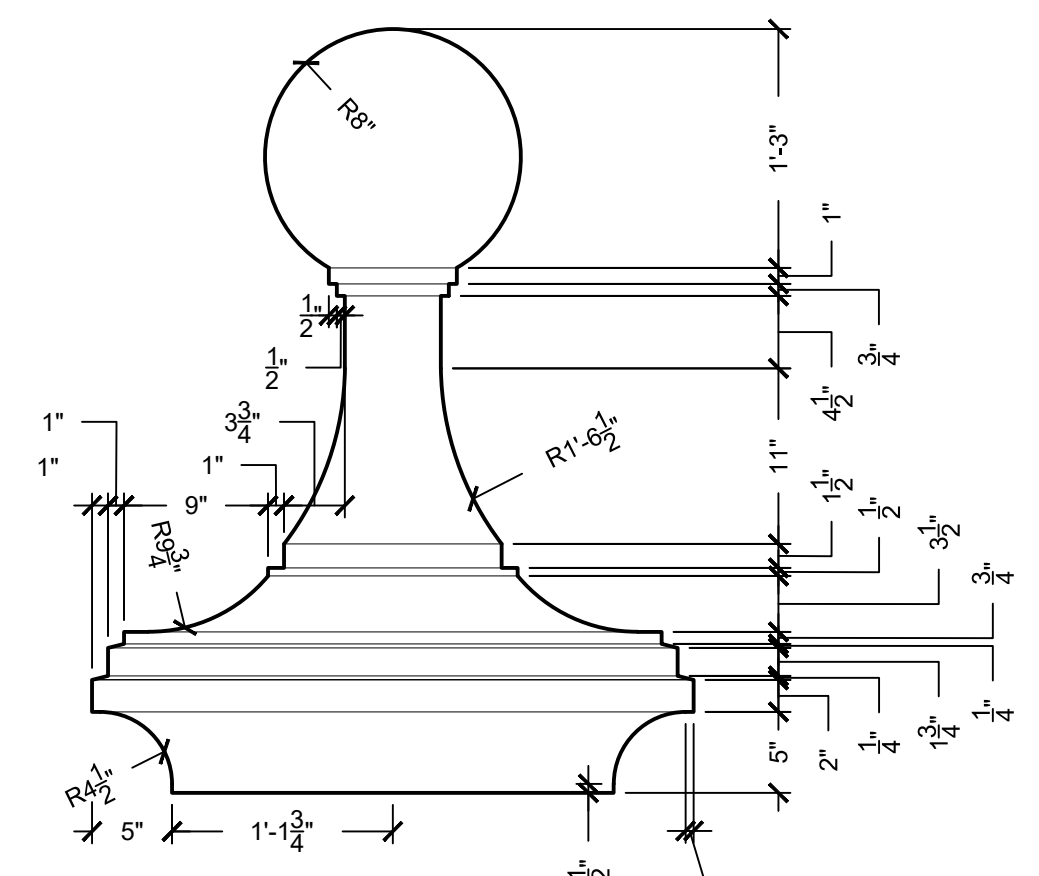

**4 COLUMN CAP, CUSTOM**  
1" = 1'-0" S-CO-FRT-06

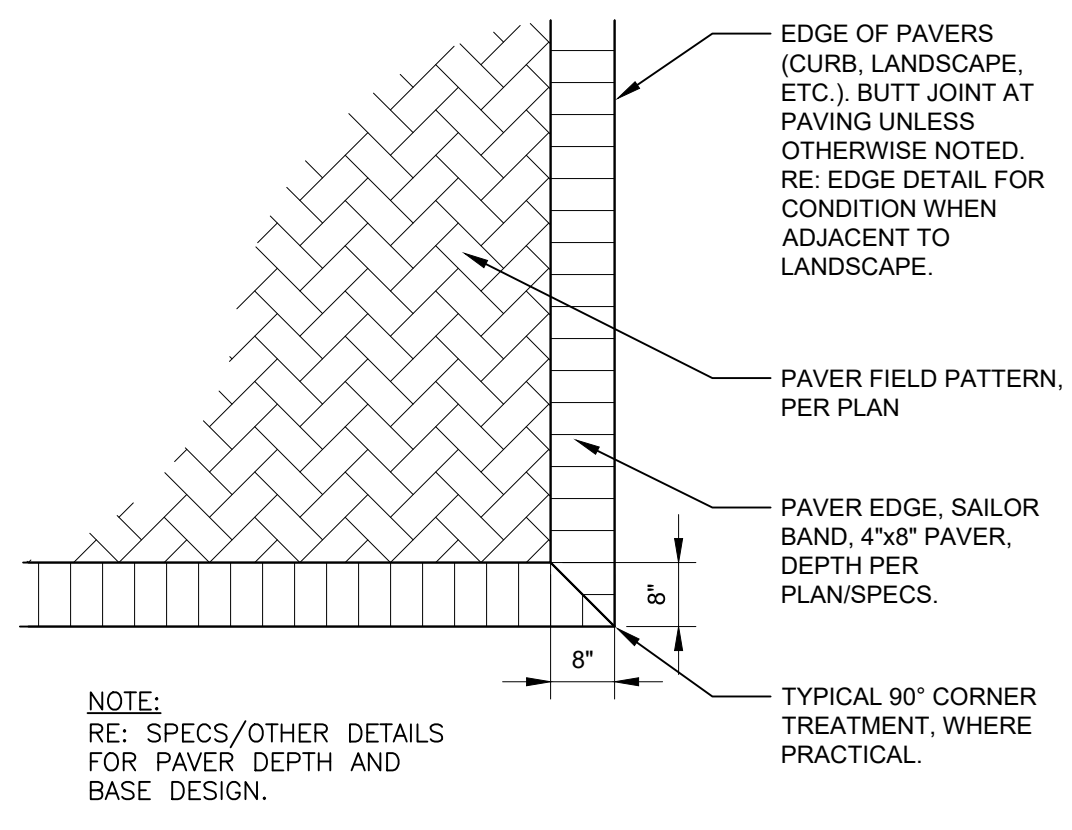

**5 PAVER EDGE BAND - PLAN**  
1/2" = 1'-0" 32 1413-13

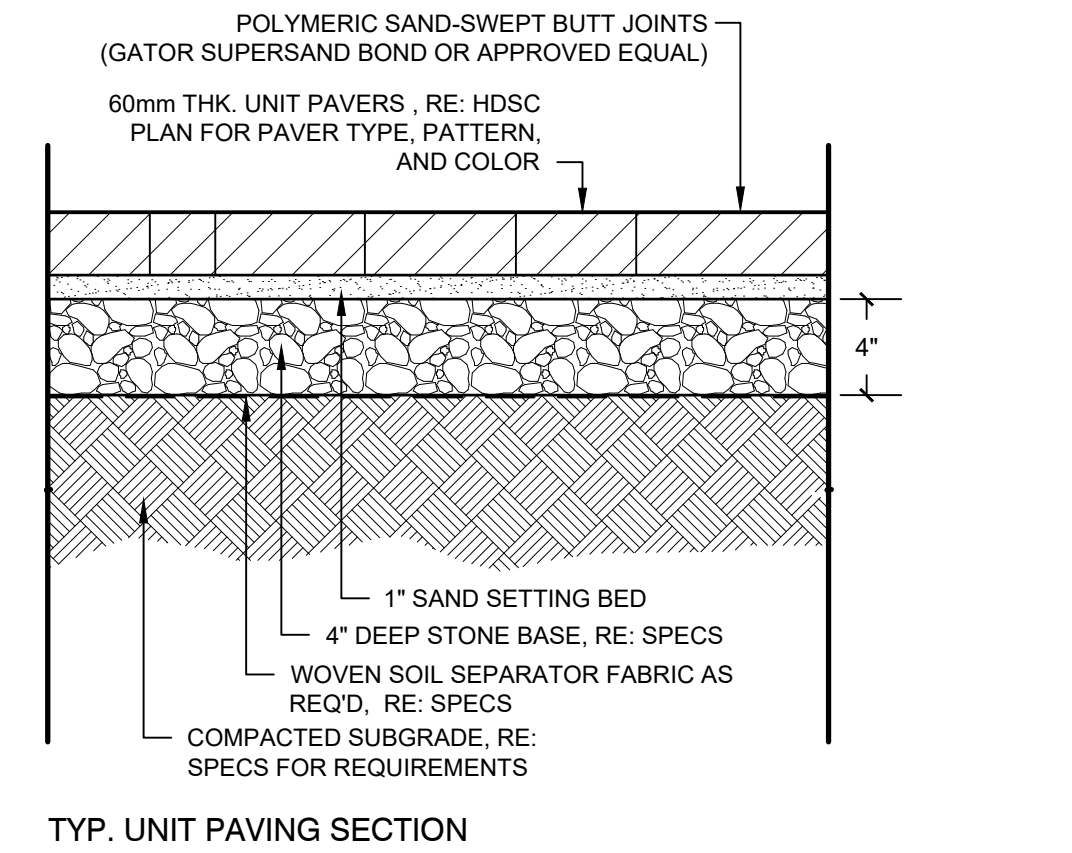
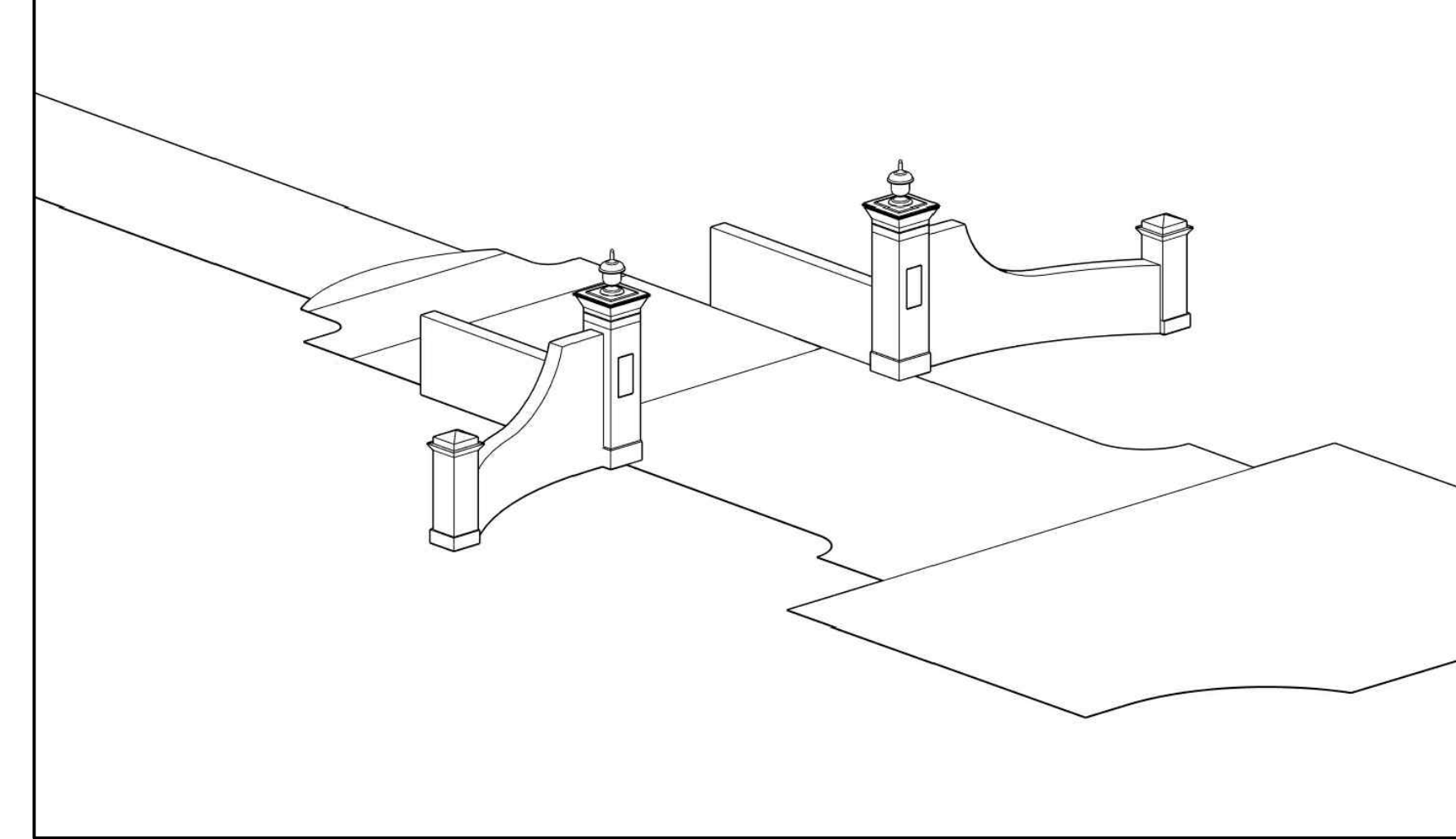
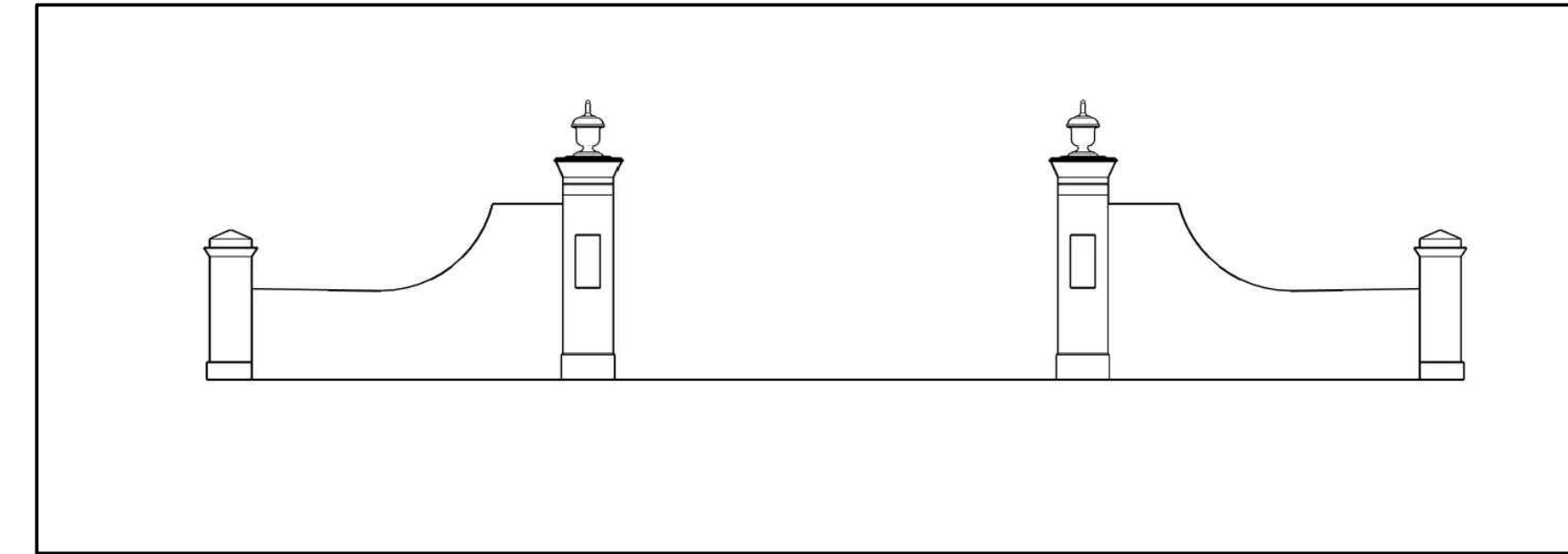

**2 PEDESTRIAN UNIT PAVING ON FLEXIBLE BASE**  
1 1/2" = 1'-0" 32 1413-16

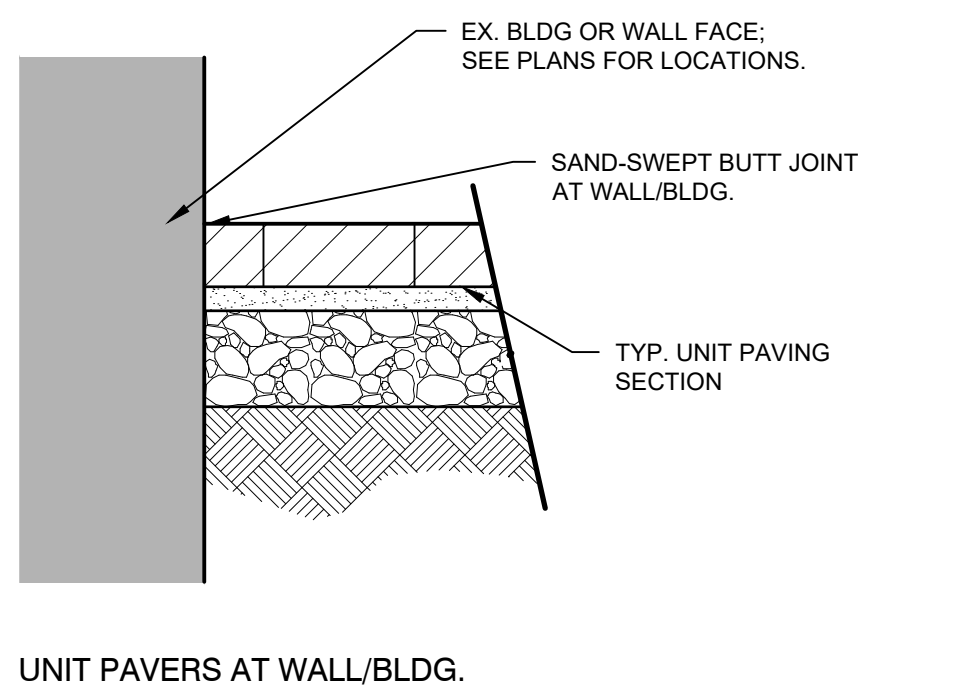

UNIT PAVERS AT WALL/BLDG.

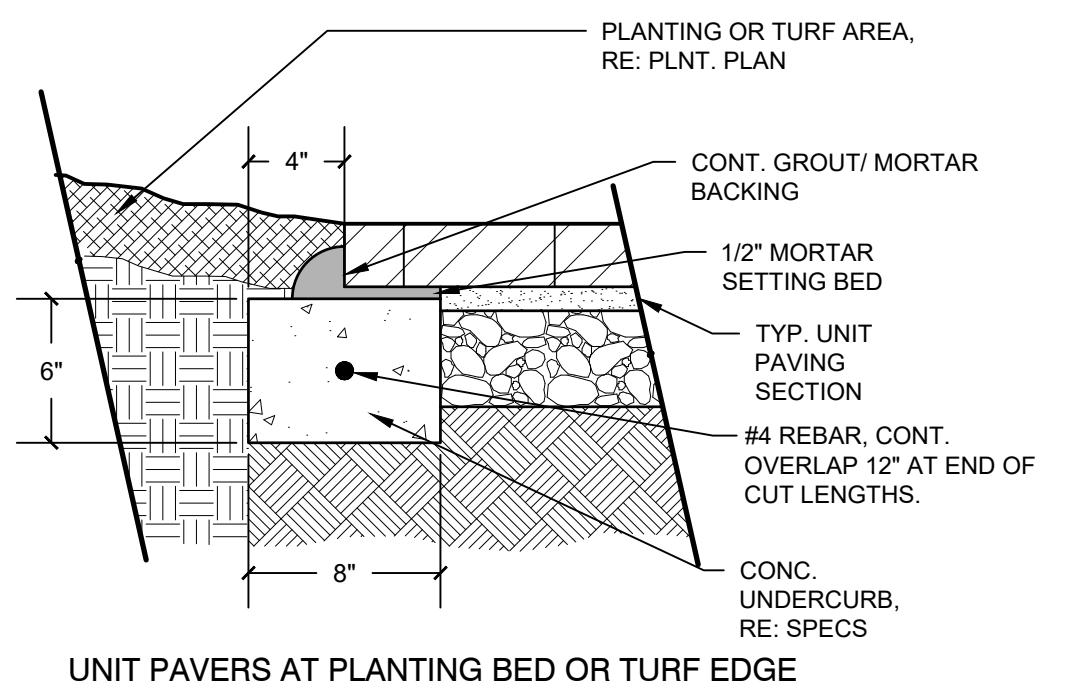

UNIT PAVERS AT PLANTING BED OR TURF EDGE

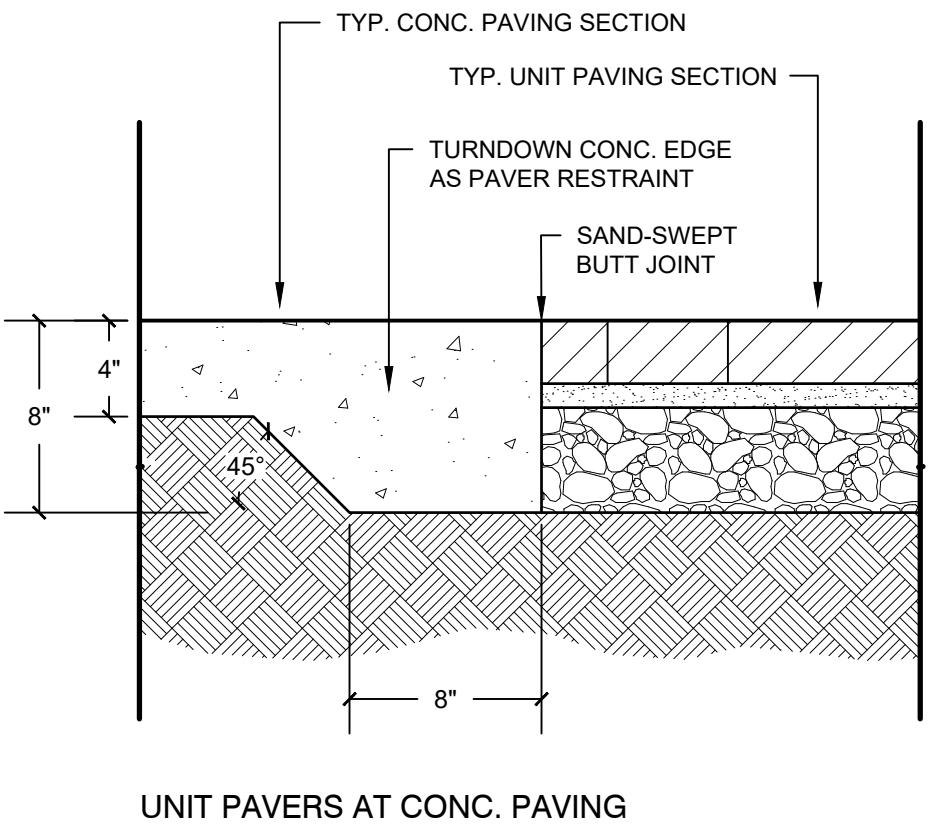

UNIT PAVERS AT CONC. PAVING

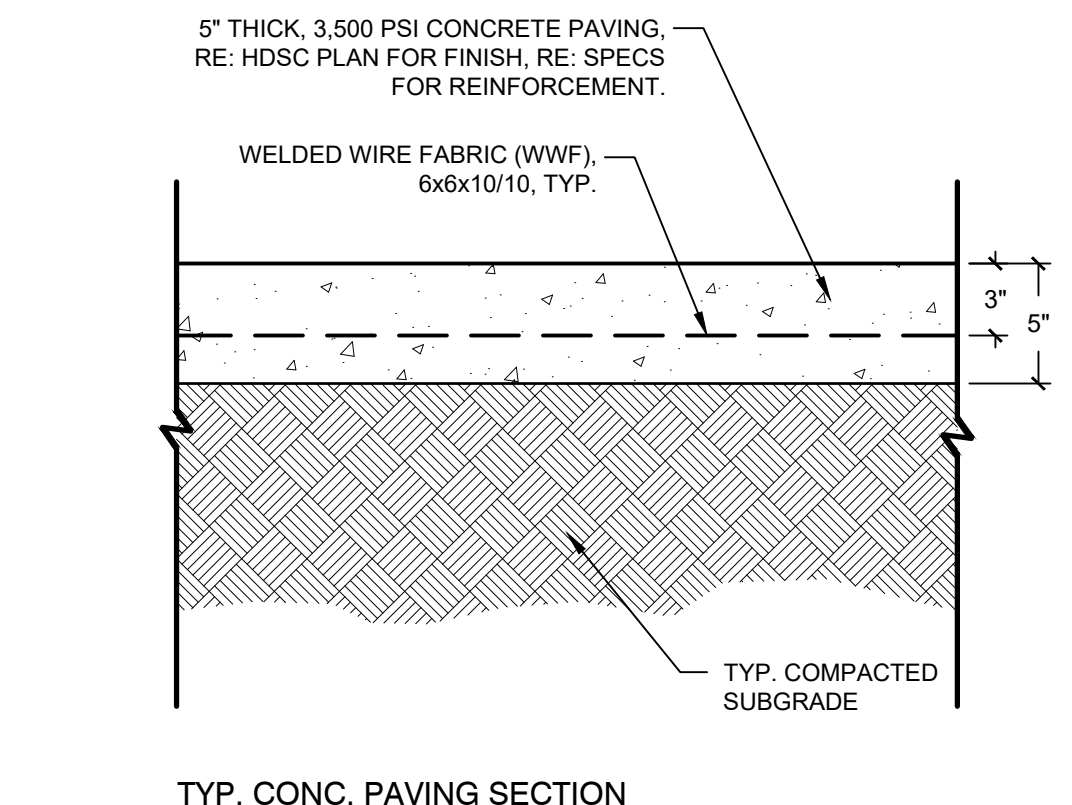

**1 VEHICULAR CONCRETE PAVING**  
1 1/2" = 1'-0" 32 1313.16-06

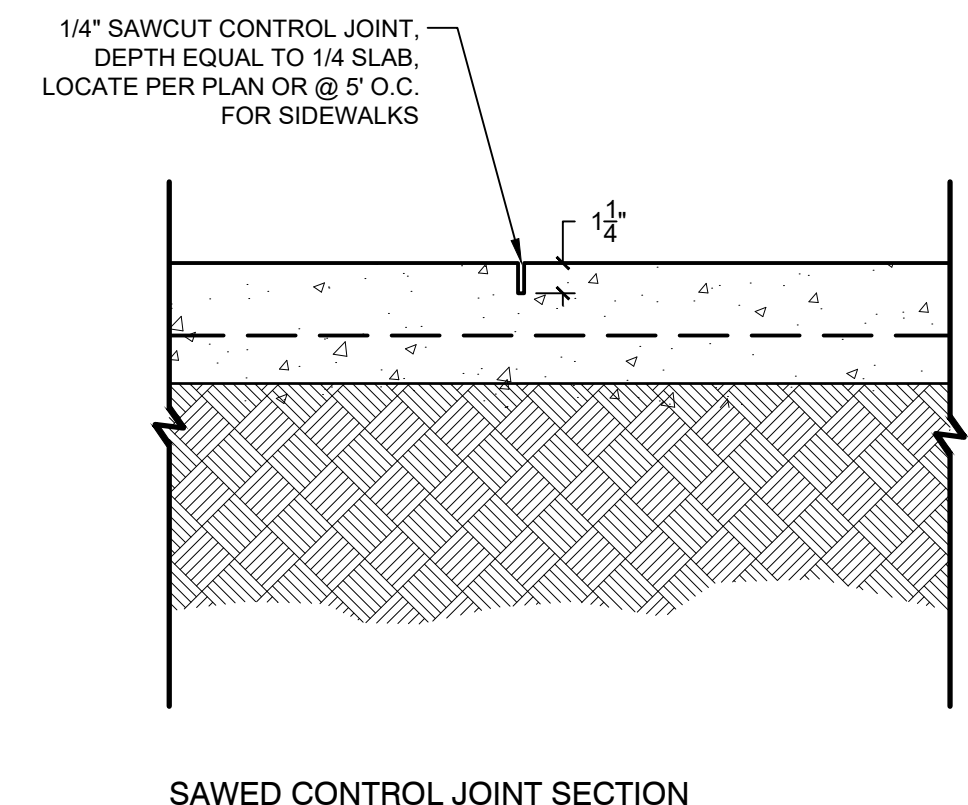

SAWED CONTROL JOINT SECTION

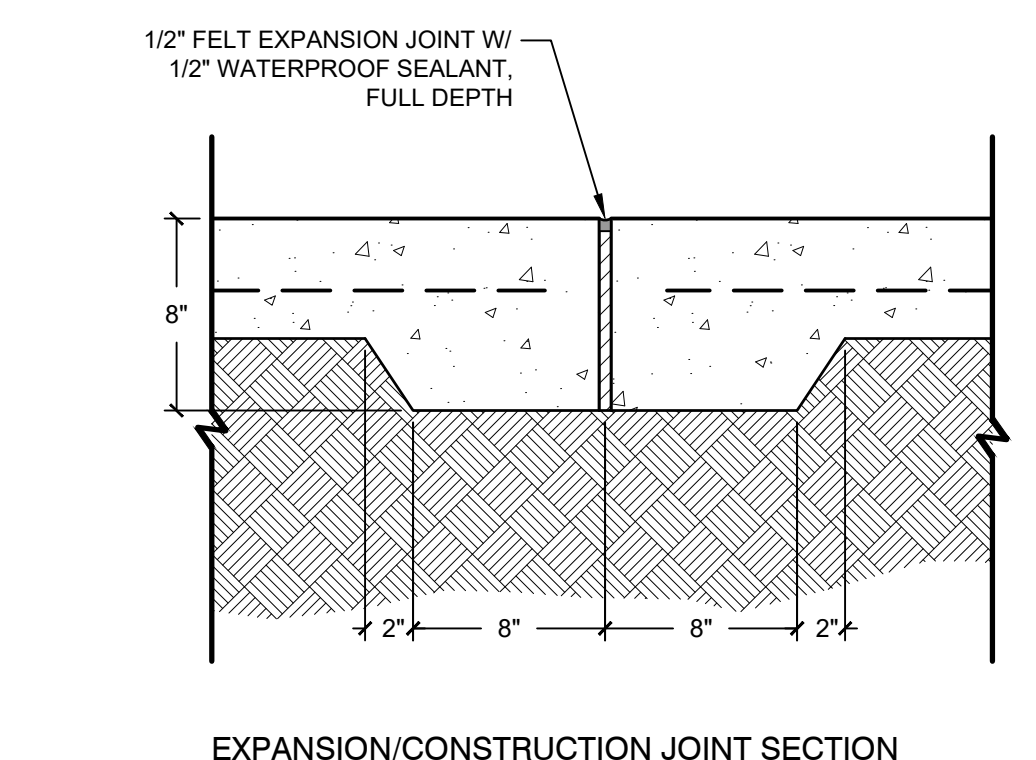

EXPANSION/CONSTRUCTION JOINT SECTION

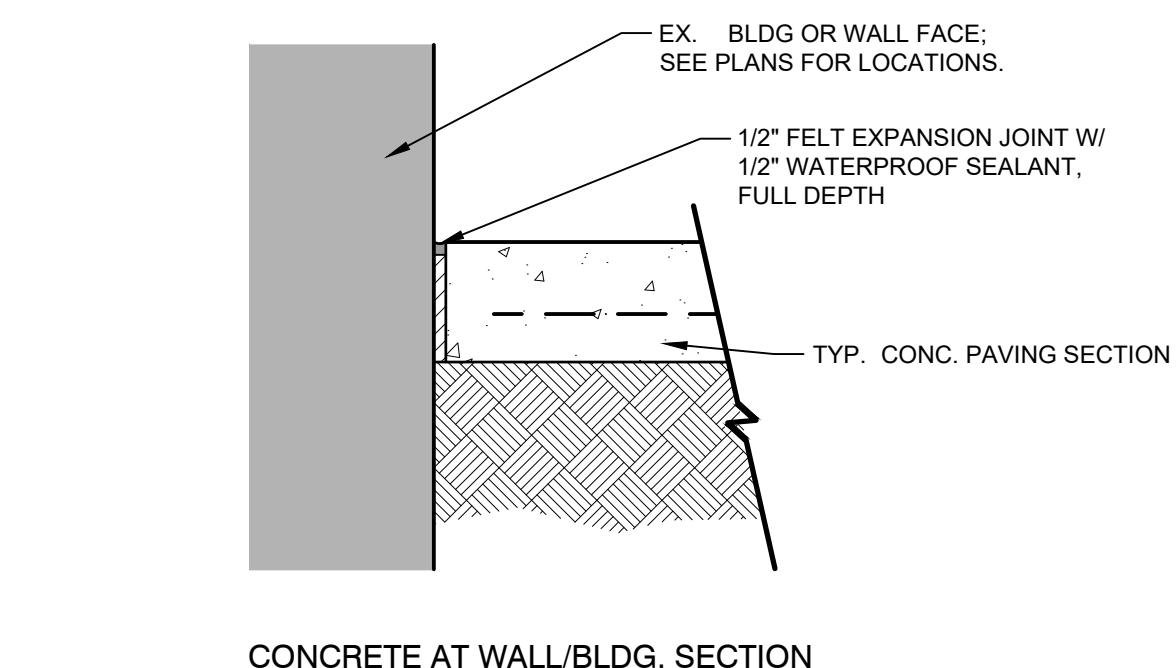

CONCRETE AT WALL/BLDG. SECTION

Revisions	
No.	Date
08.26.24	FOR OWNER CONSIDERATION

© Copyright 2024 WAS Design Inc. These documents and their contents are the property of WAS Design. Any reproductions, revisions, modifications or use of these documents without the express written consent of WAS Design is prohibited by law.

BLH Drawn  
BLH Project Manager  
LCW Principal  
226003-019 Project No.  
06.01.23 Date

Registration  
STATE OF ALABAMA  
LESTER CHAD WALKER  
REGISTERED LANDSCAPE ARCHITECT  
MEMBER  
518